

# WCP Outdoor Call Point Range

## WCP<sub>3</sub> NO/NC Contact Model (Red Versions)



### > Product Benefits

- Sealed to IP67
- Unique 'Plug & Play' installation concept
- Total 'Flex-Ability' in the choice of operating element
- Anti-Tamper facility
- Enhanced aesthetics and compact design
- Fully approved to the latest standards
- CPD Approval

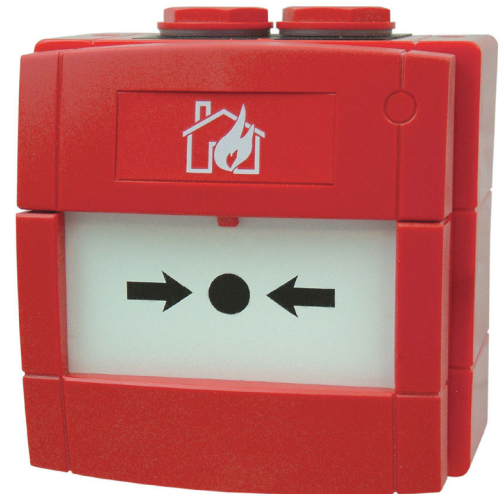

### Product Overview

Installation efficiency, flexibility and full compliance with the latest standards are at the heart of the new WCP outdoor Call Point range.

The outdoor WCP is an IP67 sealed manual call point product. The enhanced environmental protection allows the unit to be installed in many external environments where water and dirt are likely to be present, making it a true waterproof and outdoor product.

Installation time and ultimately cost, are of paramount importance to any fire or security installer. The WCP range directly reflects this need by providing a unique 'plug and play' concept designed specifically to reduce installation time. All new WCP products utilise a special terminal block, where all initial installation cabling is terminated. This terminal block is then simply connected to the back of the WCP. Simple, but effective with no re-termination required and no time wasted. In addition, all WCP products are supplied with three standard 20mm threaded cable entries, accommodating all types of surface wiring installations.

Through new standards and legislation, both break glass and re-settable operating elements can now be used within a manual call point. To provide you with the greatest 'flex-ability', the new WCP range can be configured as either a break glass or re-settable unit by simply changing from one element to another. No other additional parts or alternative products need to be ordered.

All WCP Outdoor Call Point products also help preserve the integrity of the overall system as illegal removal of the product lid will result in the call point operating and the system going in to alarm.

Full compliance with the latest standards is essential and the new WCP indoor call point range is fully approved to the latest EN54-11 standard. (*Compliant markings only*).

The WCP3A product version is supplied with one normally open and one normally closed contact. Selecting either the "Normally Open" or "Normally Closed" contact is easily achieved by simply connecting the terminal block to the required connection in the back of the WCP3 product. Single pole changeover switching can be achieved with the use of two terminal blocks.

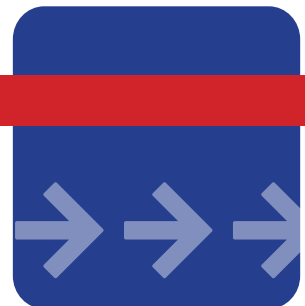

## Electrical Specification

Connection Details: See Figure .1  
 Cable Termination: 0.5-2.5mm<sup>2</sup>  
 Maximum Voltage: 30VDC  
 Switch Rating: 2 Amps

Figure .1

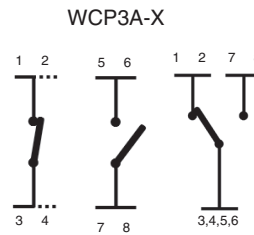

## Environmental Specification

Humidity: 0-93±3% non-condensing  
 Operating Temperature: -25°C to +70°C  
 Storage Temperature: -25°C to +70°C  
 Ingress Protection (IP) Rating: IP67  
 For RoHS, WEEE & REACH data please see [www.kac.co.uk](http://www.kac.co.uk)

## Mechanical Specification

Material: PC/ABS  
 Weight: 350g  
 Colour: Red, Ral 3001

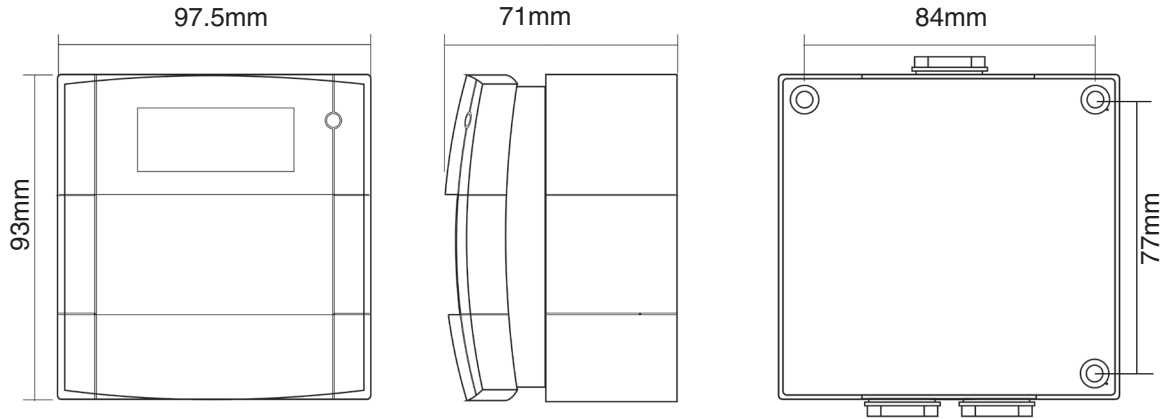

## Ordering Information

Model	Electrical Configuration	Mounting Element	Operating	Markings
Non-Stock				
WCP3A-R000SG-K013-01	N/O & N/C Contacts 30VDC	Surface	Glass	EN54-11
WCP3A-R000SF-K013-01	N/O & N/C Contacts 30VDC	Surface	Flexi	EN54-11
WCP3A-RC01SG-K013-01	single pole change over contacts 30VDC	Surface	Glass	EN54-11
WCP3A-RC01SF-K013-01	single pole change over contacts 30VDC	Surface	Flexi	EN54-11

N/O = Normally Open Contact  
 N/C = Normally Closed Contact

### Accessories

Code	Description
SC070	Pack Of Ten Test Keys
KG1 x 5	Pack Of Five Glass Elements <i>(Also available in packs of 10, 25 &amp; 50)</i>
PS210	Flexible Operating Element
PS200	Plain Hinged Cover
SC071	Pack Of Twenty Terminal Blocks

### > KAC Alarm Company Ltd

KAC House, Thornhill Road,  
 North Moons Moat, Redditch,  
 B98 9ND, United Kingdom  
 Tel: +44 (0) 1527 406655  
 Fax: +44 (0) 1527 406677  
 e-mail: [marketing@kac.co.uk](mailto:marketing@kac.co.uk)

