

## Intelligent Call Point WCP3A

### Overview

---

- Sealed to IP67
- Unique 'Plug & Play' installation concept
- Total 'Flex-Ability' in the choice of operating element
- Anti-Tamper facility
- Enhanced aesthetics and compact design
- Fully approved to the latest standards



166b

### Description

---

Installation efficiency, flexibility and full compliance with the latest standards are at the heart of the new WCP Outdoor Call Point range.

The outdoor WCP is an IP67 sealed manual call point product. The enhanced environmental protection allows the unit to be installed in many external environments where water and dirt are likely to be present, making it a true waterproof and outdoor product.

Installation time and ultimately cost, are of paramount importance to any fire or security installer. The WCP range directly reflects this need by providing a unique 'plug and play' concept designed specifically to reduce installation time. All new WCP products utilise a special terminal block, where all initial installation cabling is terminated. This terminal block is then simply connected to the back of the WCP. Simple, but effective with no re-termination required and no time wasted. In addition, all WCP products are supplied with three standard 20mm knock outs for cable entries, accommodating all types of surface wiring installations.

Through new standards and legislation, both break glass and re-settable operating elements can now be used within a manual call point. To provide you with the greatest 'flex-ability', the new WCP range can be configured as either a break glass or re-settable unit by simply changing from one element to another. No other additional parts or alternative products need to be ordered.

All WCP Outdoor Call Point products also help preserve the integrity of the overall system as illegal removal of the product lid will result in the call point operating and the system going in to alarm.

Full compliance with the latest standards is essential and the new WCP indoor call point range is fully approved to the latest EN54-11 standard.

The WCP3A product has the System Sensor protocol embedded. A version of this call point with built in isolation is also available.

## Intelligent Call Point WCP3A

### Specification

Connection Details:	See Figure .1
Cable Termination:	0.5-2.5mm <sup>2</sup>
Maximum Voltage:	30VDC
Standby Current:	400µA* (non-isolation) 500µA* (isolation)
Operating Current:	7.6mA* (non-isolation) 7.6mA* (isolation)
	*figures @ 24VDC

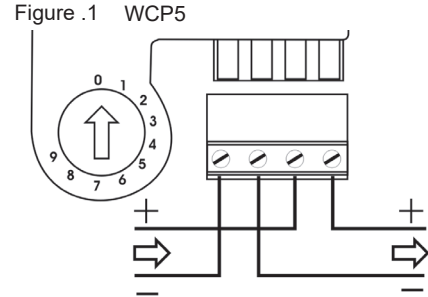

### Environmental Specification

Humidity:	0-95% non-condensing
Operating Temperature:	-10°C to +55°C
Storage Temperature:	-10°C to +55°C
Ingress Protection (IP) Rating:	IP67D

### Environmental Specification

Material:	PC/ABS
Weight:	240g 160g Surface
Colour:	Red, Ral 3001

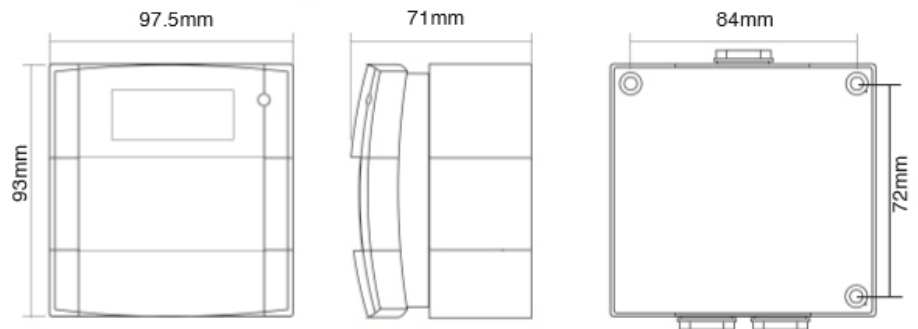

### Ordering Info

Model	Isolation	Mounting	Operating Element	Markings
Stock				
WCP5A-RP01SG-01	NO	Surface	Glass	EN54-11
WCP5A-RP01SF-01	NO	Surface	Flexi	EN54-11
WCP5A-RP02SG-01	YES	Surface	Glass	EN54-11
WCP5A-RP02SF-01	YES	Surface	Flexi	EN54-11

#### Accessories

Code	Description
SC070	Pack Of Ten Test Keys
KG1 x5	Pack Of five Glass Elements
PS210	Flexible Operating Element
PS200	Plain Hinged Cover
SC071	Pack Of Ten Terminal Blocks

ADEVA LTD. Fire Alarm Systems

Guldeste Sok. No:24 Yakacik  
Kartal / Istanbul / Turkey

Tel: +90 (0)216 5982800 Fax: +90 (0)216 5982899  
Email: info@adevafire.com www.adevafire.com

Copyright © 2009 ADEVA. All rights reserved.

All technical data is correct at time of publication and is subject to change without notice. All trademarks acknowledged. Installation information: in order to ensure full functionality, refer to the installation instructions as supplied.